

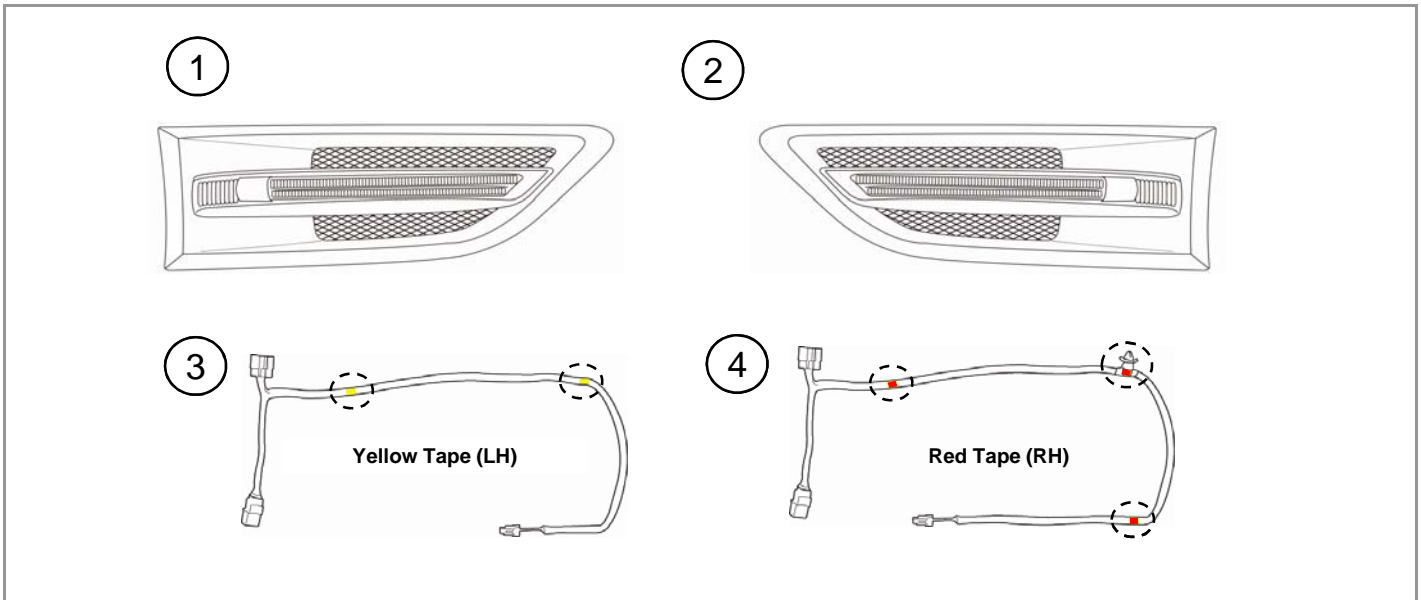

# KIA Genuine Approved Accessories

## Kit Overview



No.	Qty.	Description	No.	Qty.	Description	No.	Qty.	Description
1	1	LAMP & GANISH ASS'Y	9			17		
2	1	LAMP & GANISH ASS'Y	10			18		
3	1	CONNECTOR (LH)	11			19		
4	1	CONNECTOR (RH)	12			20		
5			13			21		
6			14			22		
7			15			23		
8			16			24		



## Hardware Overview

A		F	K	P	U
4	Wire Tie				
B		G	L	Q	V
C		H	M	R	W
D		I	N	S	X
E		J	O	T	Y

<b>Hardware Kit Total</b>
4

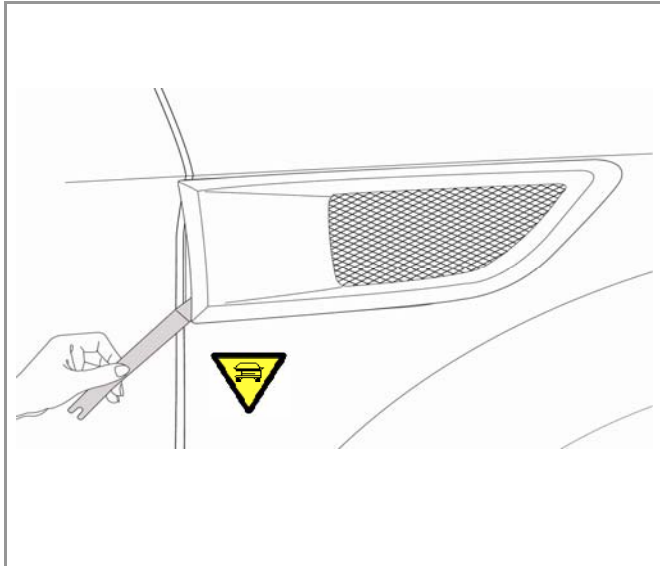
## KIA Genuine Approved Accessories (Installation)



	Nylon Removal Tool	<b>1</b>
<b>N O T E</b>	Carefully dislodge the vehicle fender garnish (as shown) with the nylon removal tool as shown in the drawing. Perform this action on the left and right hand fender.	
	Be careful not to damage the vehicle panels when performing this step. Do Not pry the fender garnish from the forward end. See step two for the proper method to dislodge.	

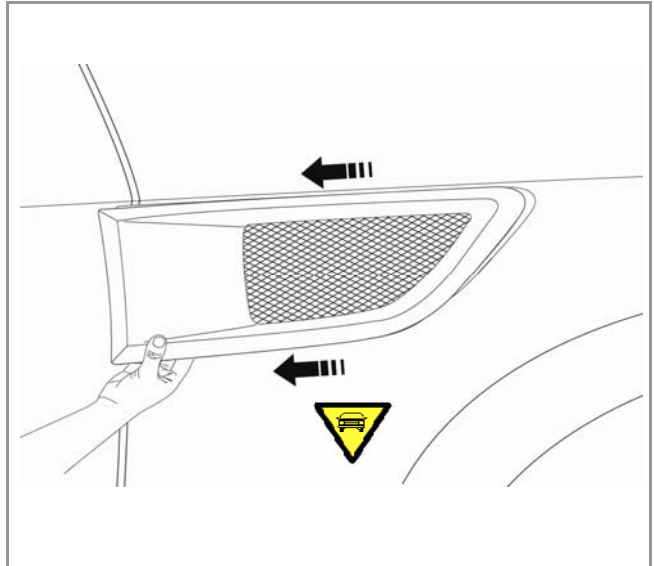

		<b>2</b>
<b>N O T E</b>	Using only your hands slide the garnish towards rear of vehicle to dislodge from the fender. Discard the fender garnish.	
	Be careful not to damage the vehicle panels when performing this step.	

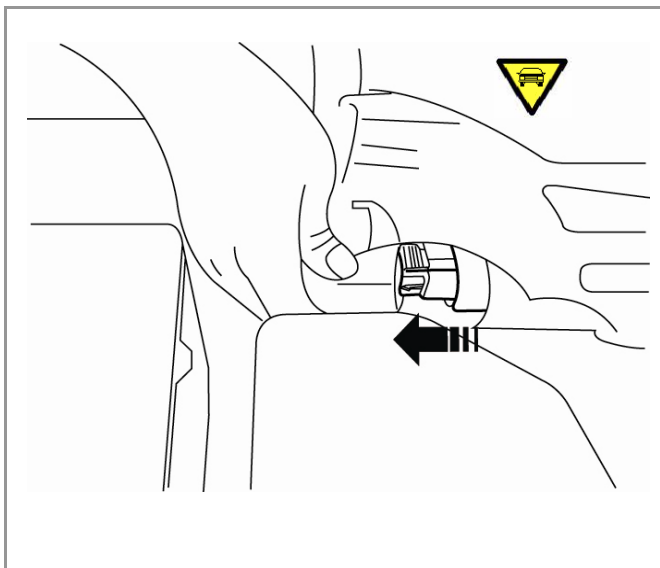

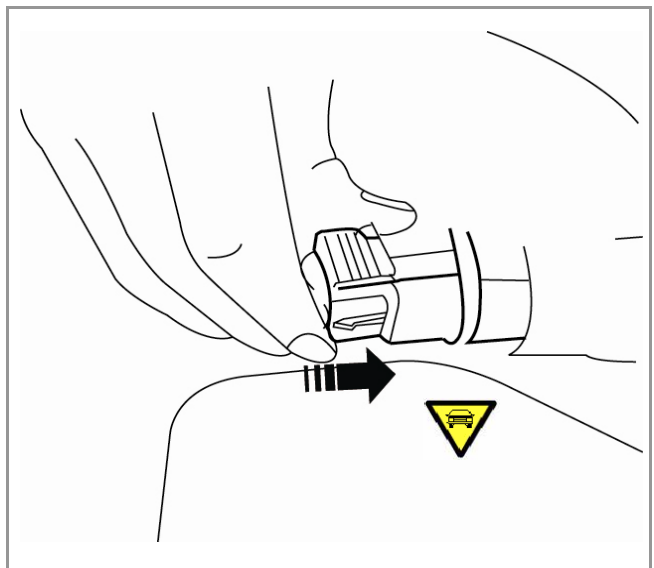

		<b>3</b>
<b>N O T E</b>	Remove the head lamp connector from the left hand lamp bezel.	
	Be careful not to pull on the wires of the harness when removing the connector.	



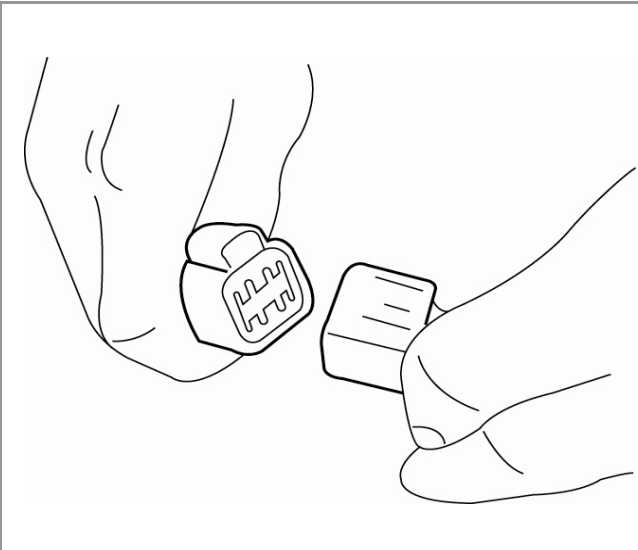

		<b>4</b>
<b>N O T E</b>	Install the T-harness connector into the left hand lamp bezel.	
	Ensure that the connector is fully inserted and that the connector locks into position.	

## KIA Genuine Approved Accessories (Installation)

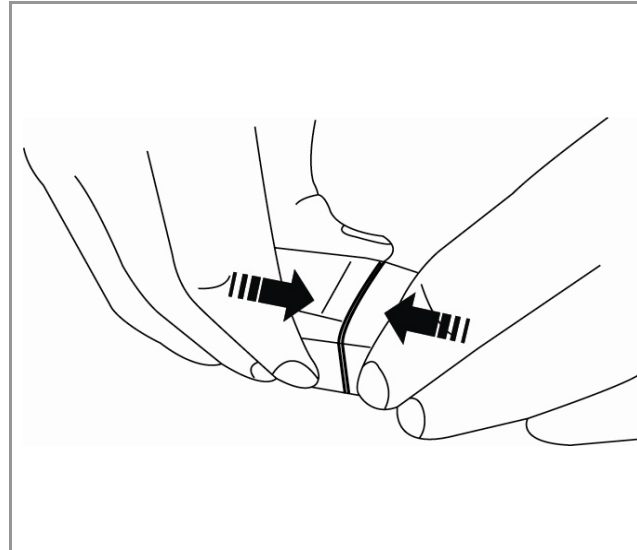

		<b>5</b>
<b>N O T E</b>	Match up the left hand T-harness with the vehicle connector removed in step 3.	
	Ensure that the correct T-harness is used for this step prior to proceeding.	



		<b>6</b>
<b>N O T E</b>	Connect the vehicle harness with the T-harness as shown in the drawing.	
	Ensure that a positive connection between the two connectors is performed.	

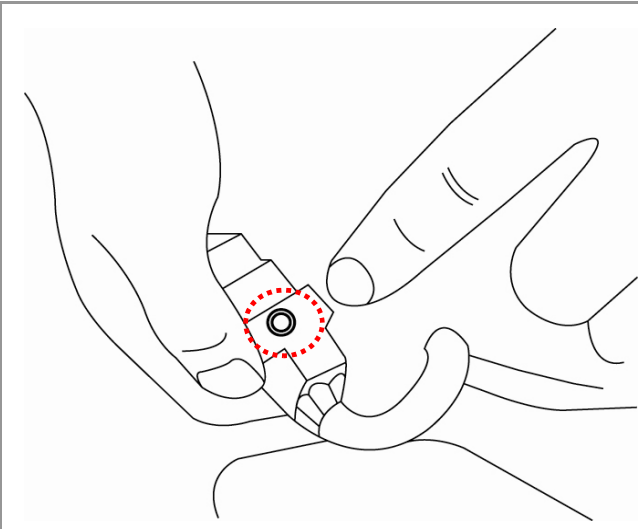

Clip on T-harness shown for Reference

		<b>7</b>
<b>N O T E</b>	Remove the original vehicle harness clip from the left head lamp housing bracket.	
	Do not damage the head lamp housing.	

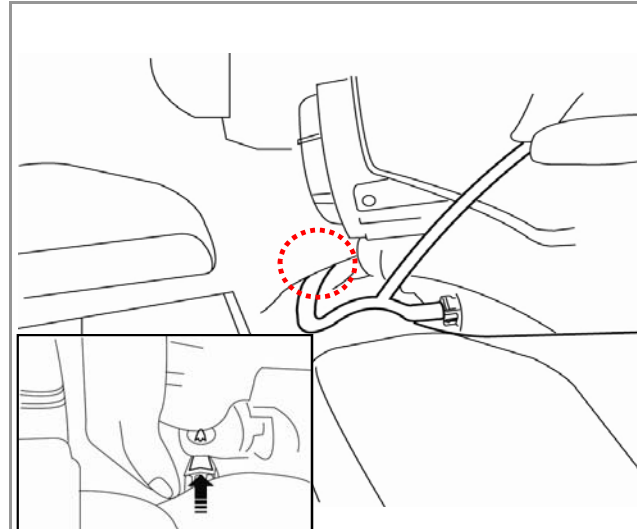

		<b>8</b>
<b>N O T E</b>	Connect the T-harness with clip to the head lamp housing bracket.	
	Confirm that the clip is fully inserted into the head lamp mount.	

## KIA Genuine Approved Accessories (Installation)

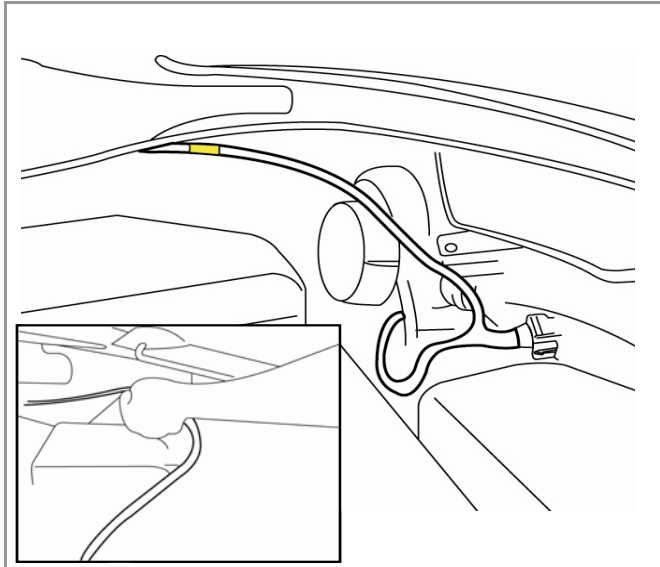

**9**

**N  
O  
T  
E**

Route the harness towards the left fender and to the outbound side of the sub frame.

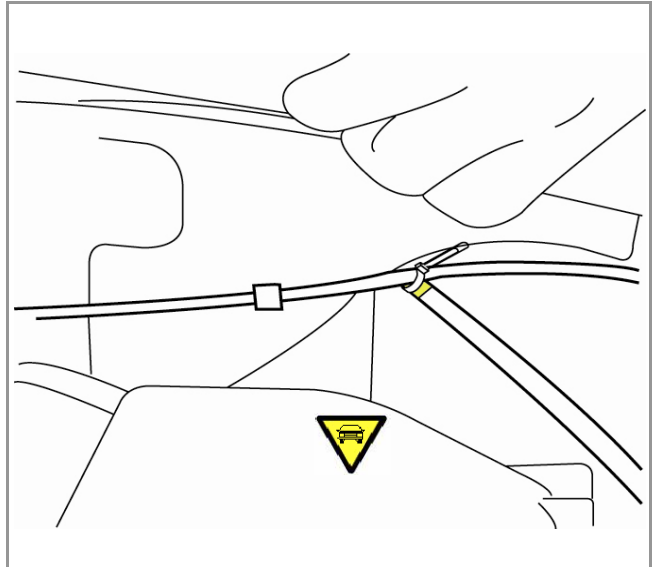

**10**



**Diagonal Cutters**

**N  
O  
T  
E**

Wire tie the T-harness to the hood release cable at the yellow tape as shown in the drawing



Be careful not to damage harness when cutting excess of the wire tie.

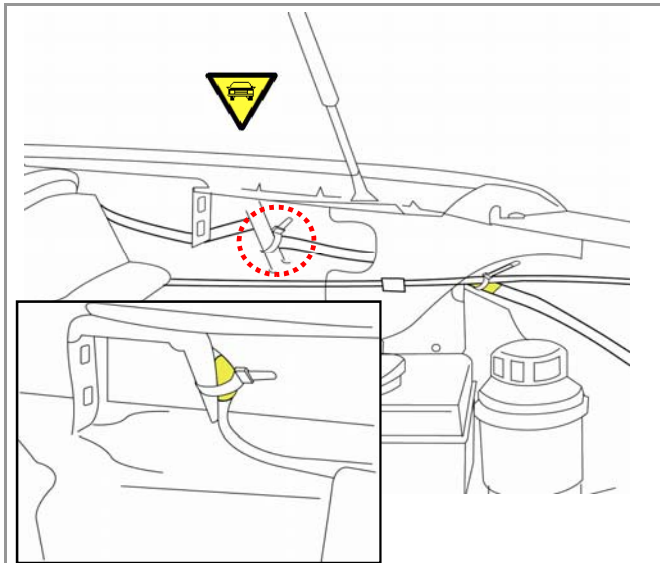

**11**



**Diagonal Cutters**

**N  
O  
T  
E**

Wire tie the T-harness to the fender bracket at the yellow tape as shown in the drawing.



Be careful not to damage harness when cutting excess of the wire tie.

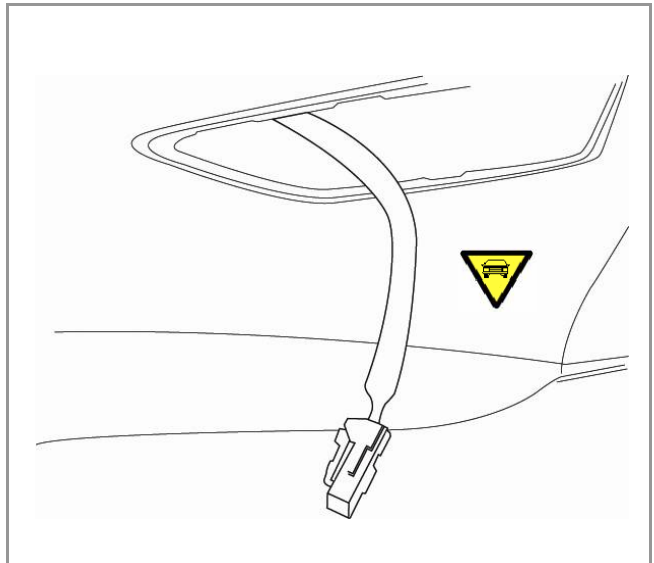

**12**

**N  
O  
T  
E**

Route the harness outside of the fender opening as shown in the drawing.



Ensure connector does not scratch surface of vehicle.

## KIA Genuine Approved Accessories (Installation)

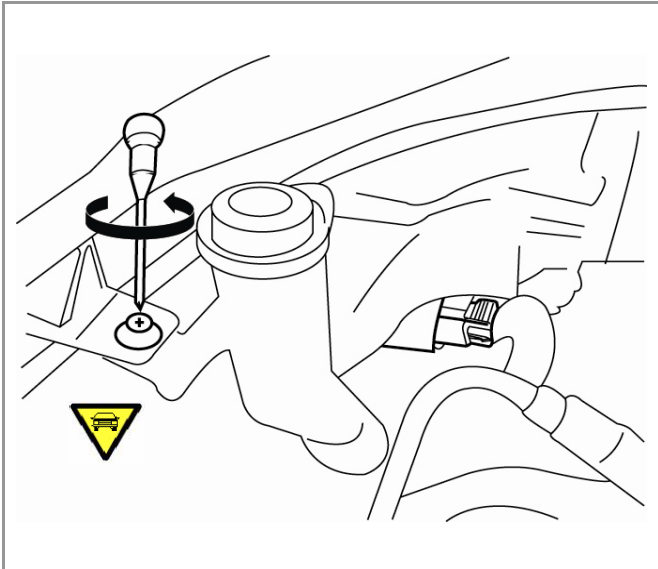

	Phillips Screw Driver	<b>13</b>
<b>N O T E</b>	Temporarily remove the screw clip used to secure the refill reservoir. DO NOT DISCARD.	
<b>N O T E</b>	Be careful not to strip the screw head.	

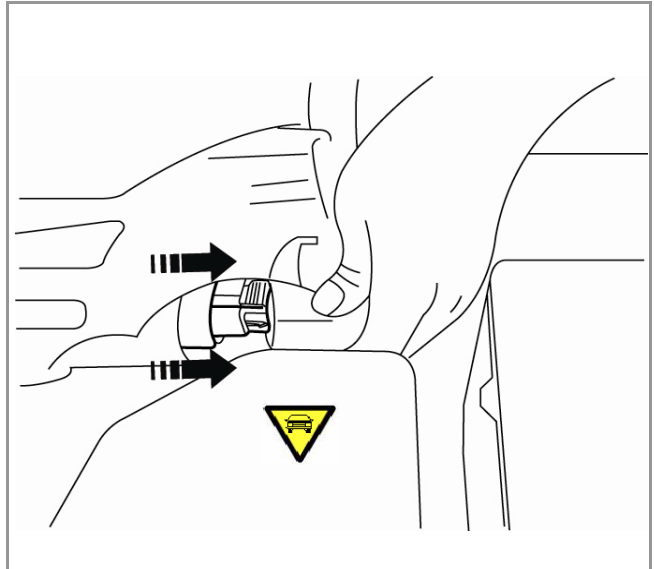

		<b>14</b>
<b>N O T E</b>	Remove the head lamp connector from the right hand lamp bezel.	
<b>N O T E</b>	Be careful not to pull on the wires of the harness when removing the connector.	

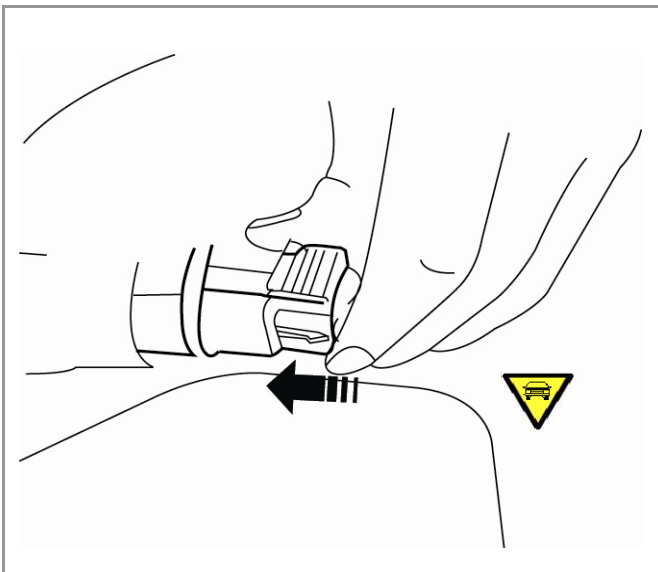

		<b>15</b>
<b>N O T E</b>	Install the T-harness connector into the right hand lamp bezel.	
<b>N O T E</b>	Ensure that the connector is fully inserted and that the connector locks into position.	

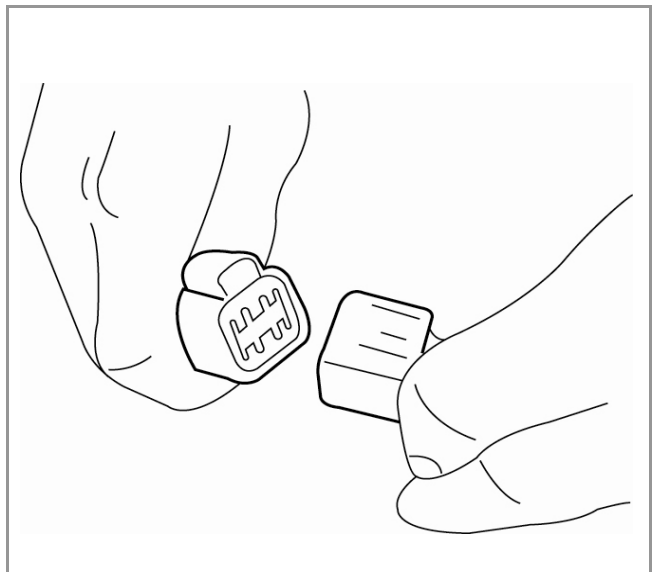

		<b>16</b>
<b>N O T E</b>	Match up the right hand T-harness with the vehicle connector removed in step 15.	

## KIA Genuine Approved Accessories (Installation)

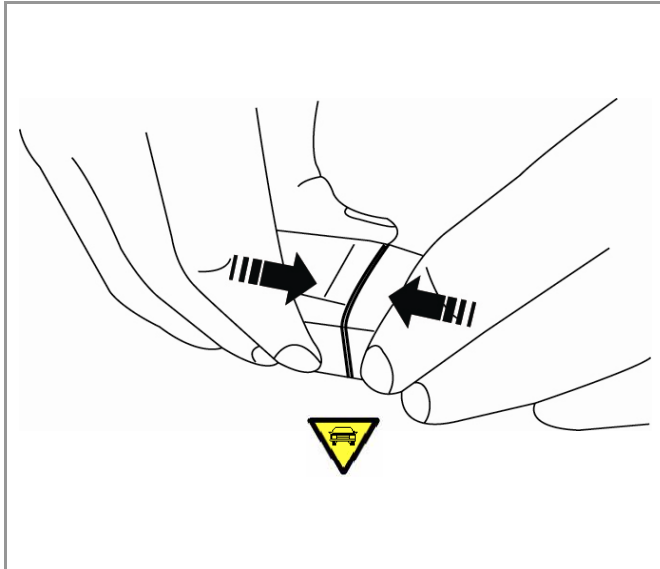

17

NOTE

Connect the vehicle harness with the T-harness as shown in the drawing.



Ensure that a positive connection between the two connectors is performed.

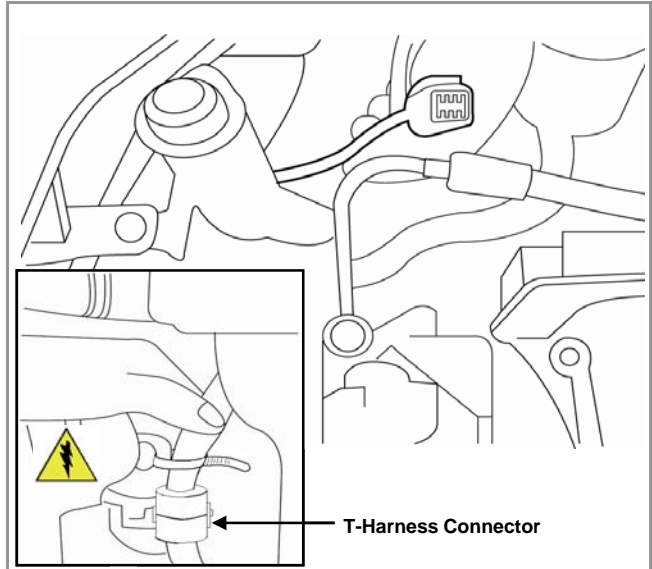

18



Diagonal Cutters

NOTE

Remove the vehicle harness connector clip from the refill upper reservoir mount and reinsert the clip into the lower reservoir mount. Wire tie the T-harness to the upper reservoir mount as shown in the drawing.



Ensure the T-harness connector clip locks into the bottle securely. **FAILURE** to install the removed original vehicle harness clip into the lower position on the reservoir bottle could result in this harness interfering with the pulley/belt causing major damage.

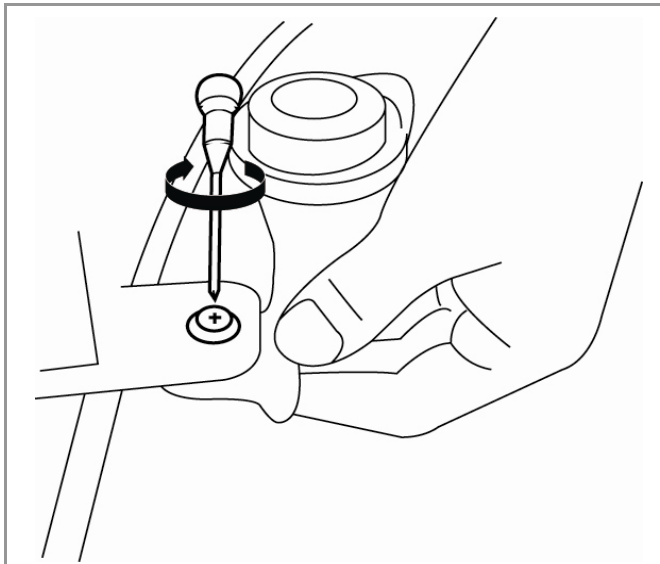

19



Phillips Screw Driver

NOTE

Reinstall the reservoir bottle screw to secure to the vehicle.

Ensure that the screw is fully seated.

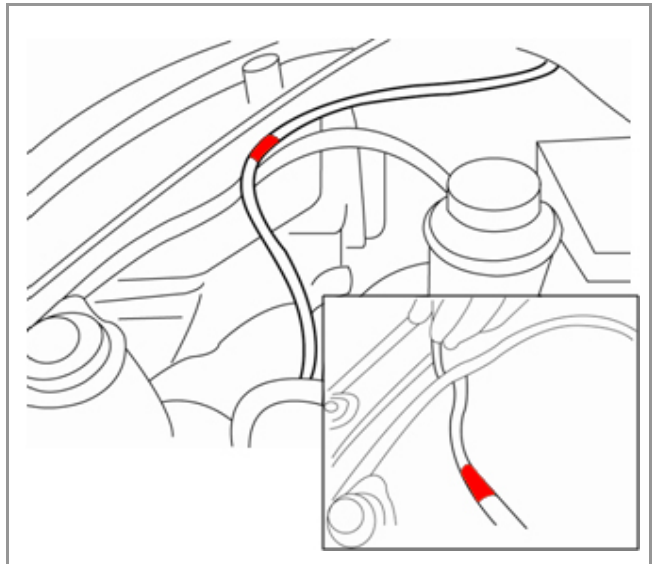

20

NOTE

Route the harness towards the right fender as shown in the drawing.

## KIA Genuine Approved Accessories (Installation)

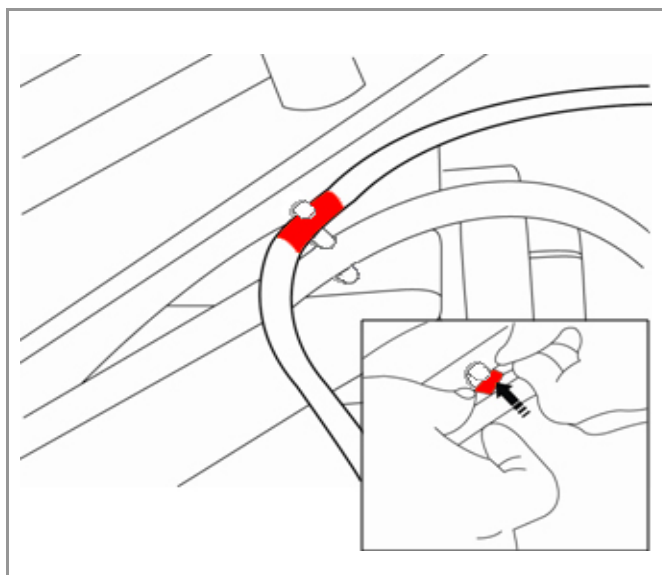

**21**

**N  
O  
T  
E**

Insert the harness into the vehicle clip above the rubber hose as shown in the drawing.



Ensure that the harness is fully seated into the clip.

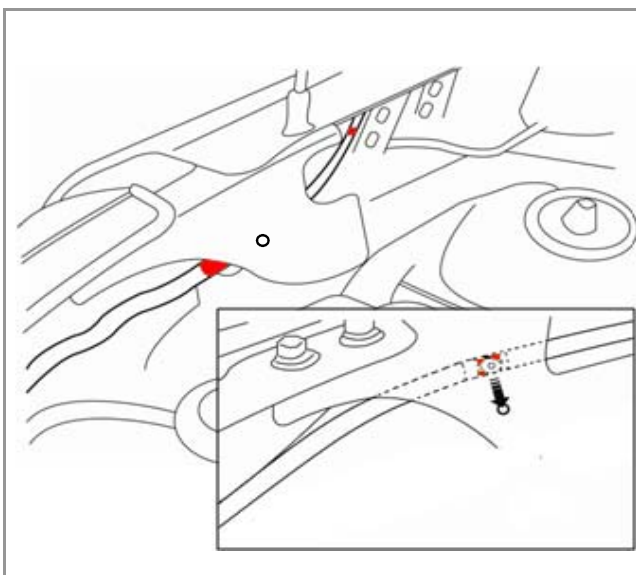

**22**

**N  
O  
T  
E**

Route the harness towards the right fender and to the outbound side of the sub frame as shown in the drawing.  
Lock the harness onto the fender sub panel using the provided clip insert into the hole as shown.



Ensure that the clip is fully inserted through the sub-frame hole.

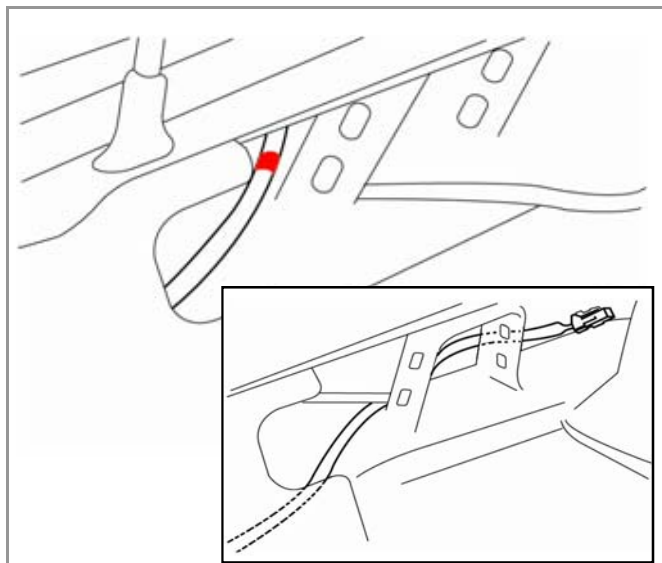

**23**

**N  
O  
T  
E**

Route the harness outbound as shown in the drawing.

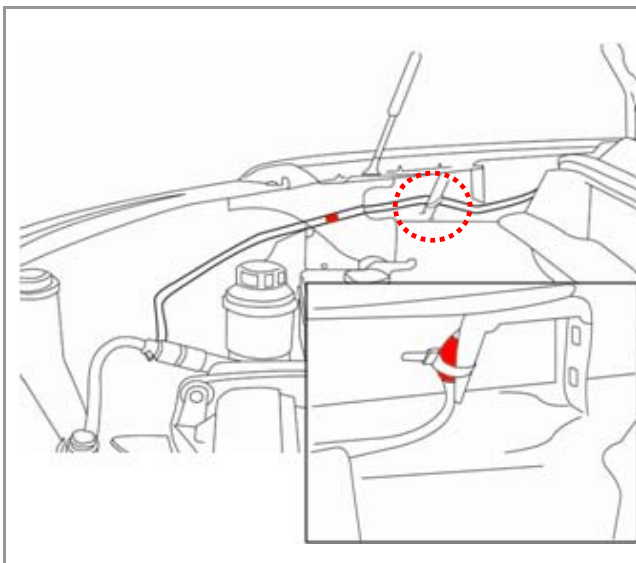

**24**

**Diagonal Cutters**

**N  
O  
T  
E**

Wire tie the T-harness to the fender bracket at the red tape as shown in the drawing.



Be careful not to damage harness when cutting excess of the wire tie.



## KIA Genuine Approved Accessories (Installation)

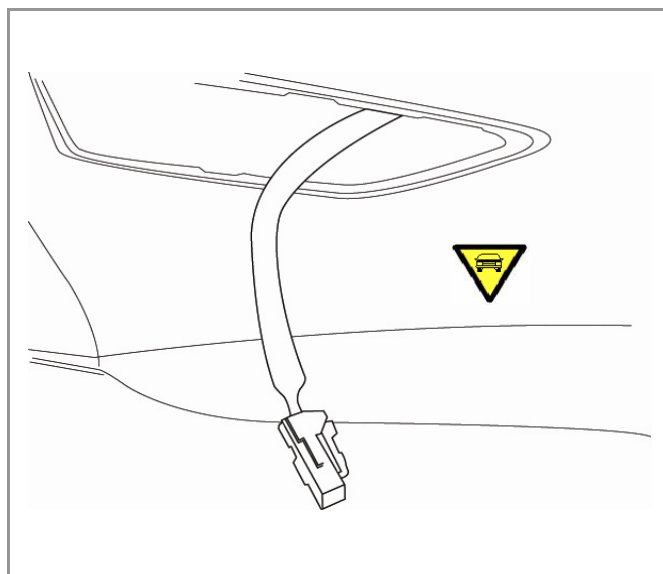

25

**N  
O  
T  
E**

Route the harness outside of the fender opening as shown in the drawing.

Ensure connector does not scratch surface of vehicle.

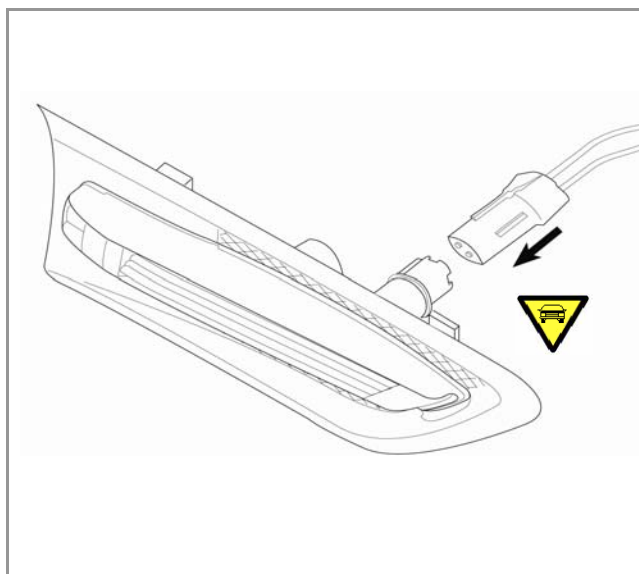

26

**N  
O  
T  
E**

Connect the T-harness two (2) pin connector to the fender lamp garnish.

Ensure that the proper fender lamp garnish is used.

Ensure that the harness is fully inserted and a positive connection is made between the fender lamp garnish and T-harness.

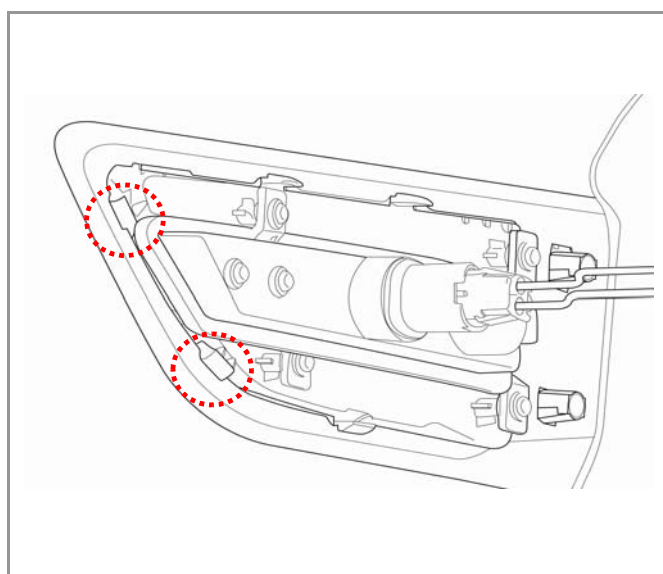

27

**N  
O  
T  
E**

**IMPORTANT...** prior to installing the fender lamp garnish into the fender, test the system to ensure that it functions properly. Once installed the fender lamp garnish is extremely difficult to remove without damaging.

Reconnect the Battery negative lead originally removed.  
Turn the ignition key to the ON position.

Confirm that when the turn signals are turned ON (Right / Left & Hazard) that the fender lamp repeaters flash.

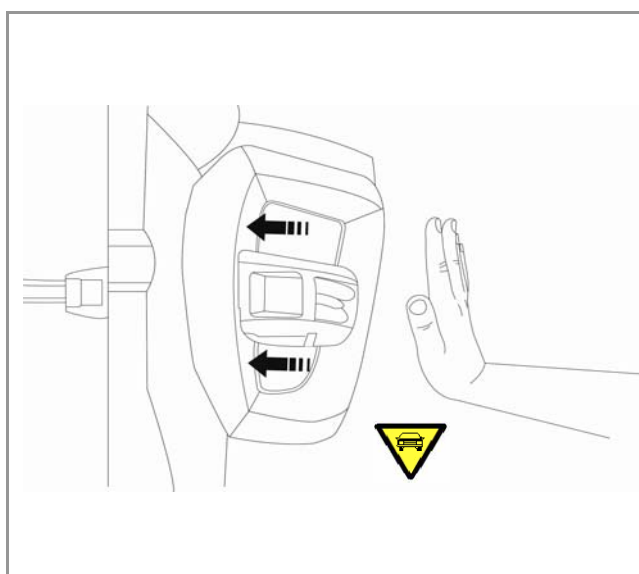

28

**N  
O  
T  
E**

Insert the front end garnish into the fender and lock into position onto the fender.

Align the aft end of the garnish (locking clips) to the fender and gently press inward until fully seated.

Inspect the garnish to ensure that ALL the tabs are installed properly into the fender.

